

\* incl. 20 [-5; +30] mm pull out

3D model is available on request or [www.hyva.com](http://www.hyva.com)

Specifications		Max. pump flow		Tipping time	
Max. working pressure	250 bar	With KO <sup>1</sup>	122 L/min	With KO <sup>1</sup>	18 sec
Weight	136 kg	Without KO <sup>1</sup>	86 L/min	Without KO <sup>1</sup>	25 sec
Working volume	36 L	With KO <sup>1</sup> below -20°C	85 L/min	With KO <sup>1</sup> below -20°C	26 sec
Total volume	39 L	Without KO <sup>1</sup> below -20°C	60 L/min	Without KO <sup>1</sup> below -20°C	36 sec
Max. cyl. load (start tipping)	195 kN			Allowable lowering time	18 sec
Max. cyl. load (end of stroke) <sup>2</sup>	82 kN				
Max. cyl. load (end of stroke) <sup>3</sup>	95 kN				

Technical notes

- This cylinder is a lifting device only.
- It should not be used as a structural member and should not be subjected to side loads.
- Tipping valve must have a pressure relief at the cylinder port set not higher than max. working pressure.
- Verify max. cyl. load.
- Working temperature range is between -40°C and +80°C.
- Max. duration of extension is 0.5 hours (excluded hard chromed stages).
- Cylinder is painted black (RAL9005) with a min. thickness conforming to the 480 hours neutral salt spray test as per ISO 9227.
- <sup>1</sup> Hyva knock-off.
- <sup>2</sup> Unsubstantial unloading (sticky load).
- <sup>3</sup> Substantial unloading.

Related documentation

- Bracket options: 015BRA10 & 015BRA13
- Mounting instructions: CYL-0031
- Oil specifications: OIL-0011
- Spec sheet explanation: CYL-0041

Configuration

Extension	1	2	3	4	5	6	7	Total
Effective diameter [mm]	129	110	91	72				4320
Stroke* [mm]	1065	1085	1085	1085				

Tipping weight

For detailed tipping calculations please refer to: <https://tipper.hyva.com>

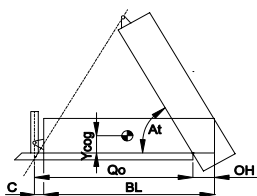

- BL body length
  - OH rear overhang
  - Ycog vert. pos. centre of gravity
  - Qo pivot length
  - C bracket length
  - At tipping angle
- stroke x 60 / Qo*

BL [mm]	5700	800	5550	800	5400	800	5400	800
OH [mm]	200	500	200	500	200	500	200	500
At [°]	46	49	47	50	49	52	49	56
Ycog [mm]	600	33	38	30	34	40	30	35
C	29	37	45	33	39	48	34	40
At	35	42		37	45		38	42

Tipping weight [ton] at maximum pressure of 250 bar for a vertically mounted cylinder and C is 158 mm

Pos.	Part no.	Description	Qty.
C01	71839111	DUST COVER FE 129-4/137-4	1
P01	74461301	PISTON FL3 S 072-1280-HC	1
P02	71853072K	SLIDER FL 072 (2 X 1/2) A22	2
P04	71822072	BOTTOM PLATE PISTON FL 072	1
P05	01745026K	CIRCLIP 63 DIN 472 (67.2x2.0)	1
P06	71870210K	O-RING PISTON BOTTOM 072	1
P07	71847100	PISTON EYE SPH. FL3 072 L=075	1
P08	01226420K	O-RING 53.57 X 3.53 MM	1
P09	71875450K	SPHERICAL BEARING D.50.3 MAINT. FREE	1
P10	01770560K	CIRCLIP 75 DIN 472 (79.5x2.5)	1
P11	71875012	PIN ROUND HEAD GROOVED 8x15 mm	2

S31	74602300	STAGE FL2 091-1275	1
S32	71802091K	PACKSET FL 091	1
S33	71853091K	SLIDER FL 091 (2 X 1/2) A22	1
S34	71851091K	OUTER STOPRING FL 091 A22	1
S35	71852091K	LIFTRING FL 091 A22	1

S21	74603300	STAGE FL2 110-1275	1
S22	71802110K	PACKSET FL 110	1
S23	71853110K	SLIDER FL 110 (2 X 1/2) A22	1
S24	71851110K	OUTER STOPRING FL 110 A22	1
S25	71852110K	LIFTRING FL 110 A22	1

S11	74604300	STAGE FL2 129-1275	1
S12	71802129K	PACKSET FL 129/HP 129	1
S13	71853129K	SLIDER FL 129 (2 X 1/2) A22	1
S14	71851129K	OUTER STOPRING FL 129 A22	1
S15	71852129K	LIFTRING FL 129 A22	1

B01	74505300	BASE FL2 149-1314-4/4BSAE-190	1
B02	71802149K	PACKSET FL 149/HP 150	1
B03	71825420	BOTTOM PLATE FL2 149	1
B04	71870030K	SEAL BOTTOM PLATE FL 149	1
B05	71820149	LOCKING PLATE FL 149	3
B06	01732055K	BOLT HEX M8X20X1.25 SET 6 PCS	1
B07	01732559K	WASHER SPRING M8 SET 6 PCS	1

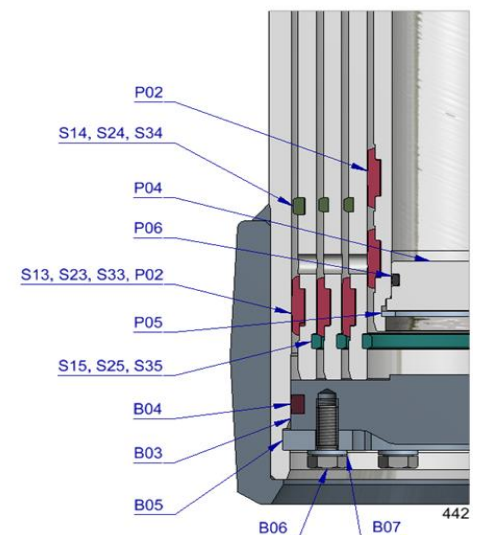
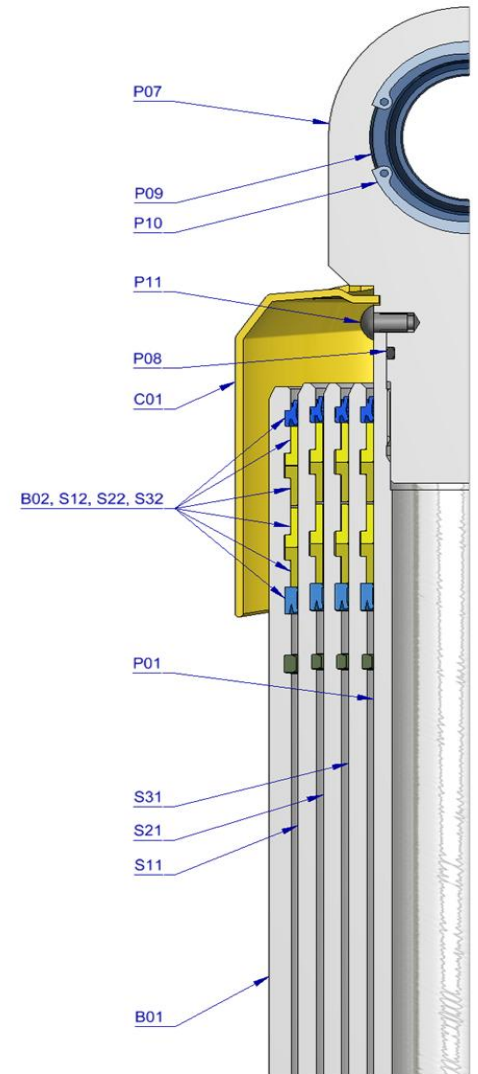

Seal kit complete

71908440K	Consists of all packsets with packset grease and O-rings
-----------	--

Notes

The inner stopring and piston bottom are pre-mounted on spare bases, stage and pistons. Therefore, when ordering new tubes, it is not required to order these parts separately.

For repair instructions see: CYL-0040. Serial no. is located on type plate and near type plate support.